

Biological Sewage Treatment System **DVZ - JZR** **“BIOMASTER”**[®]

- Type approved according to IMO Resolution MEPC. 159 (55)
- High purification effect
- Stainless steel design
- Optimum Bio-process monitoring
- High flexible, it can be scaled up or down with a number of JZR or DVZ-BMSU modules
- High Biomass concentration tolerance
- Defined retention time
- No movable part, it is not sensitive against shock, vibration and movement
- Easy to handle



Biological Sewage Treatment System:

DVZ - JZR

System Description

The black and grey water will be sent to the buffer by vacuum and gravity. The sewage from the galley will pass a fat trap before entering the buffer tank.

The buffer tank has to buffer the pick loads of wastewater and homogenise it. There is a bottom aerator in the buffer tank for mixing and conditioning the waste water during the buffering process.

The transfer pump will deliver the wastewater to the STP and feed it into the recirculation loop of the JZR via double filter. The recirculation pump mixes the inlet wastewater with the activated wastewater of the JZR reactor and feeds it into the JZR reactor bleed loop via the two media nozzle.

Due to the injector effect of the two media nozzle air is sucked in from outside via a central air pipe. This air flow will be boosted by additional pre-compressing through the blower.

The real amount of air flow will be indicated by the flow indicator. The two media nozzle produces a perfect homogenous mixture with very small dispersed air bubbles and small biological flocks, which will be injected into the special JZR primer reactor.

The JZR primer reactor is equipped with special hydraulic inserts, which cause different hydraulic flow loops. These loops multiply the aeration effect. The primer JZR reactor is integrated in an outer bioreactor, which is also equipped with a circulation feature. The recirculation loop is designed in this way that it is possible to reach primary aeration and secondary saturation or both using the outer reactor space.



“BIOMASTER”[®]



The biological purified wastewater flows through a calming zone with guide tools and overflow weir to the intermediate tank. This tank works as a pump sump and buffer for the pump and as dry- and overflow protection for the STP system.

For producing clean water, the biomass/ water selection will be done with a special BMSU-Membrane, which is designed and manufactured by DVZ-SERVICES GmbH.

The used principle applied is the cross flow membrane filtration.

The bleed pump forces a permanent high recirculation flow (bleed) inside the membrane tubes, and the Feed Pump feeds the biologically treated water in the recirculation loop.

Because of feeding the biologically treated water with a Feed Pump, the pressure on the feed side of the membrane will increase and forces a permeate flow (flux, clean water).

A special automatic conditioning - and cleaning system (CIP) will keep the membrane in good working condition.

The amount of permeate (actually produced clean water) flow will be indicated by the flow meter.

Because of using the membrane filtration for biomass selection, the produced clean water is free of all solids, coli bacteria and other pollutants (acc. to IMO Res. MEPC.159 (55)), and therefore does not require any additional disinfection.

The whole JZR-Sewage Treatment Plant is controlled automatically by PLC, which allows ongoing observation and control of process relevant parameters by sensors.



DVZ-SERVICES GmbH
Boschstrasse 9 D-28857 Syke

Phone: +49 (0)4242 - 16938 - 0

Fax: +49 (0)4242 - 16938 - 99

E-Mail: info@dvz-services.de

www.dvz-services.de

Main dimensions of the standard series skid mounted units

(Custom made solutions on request)

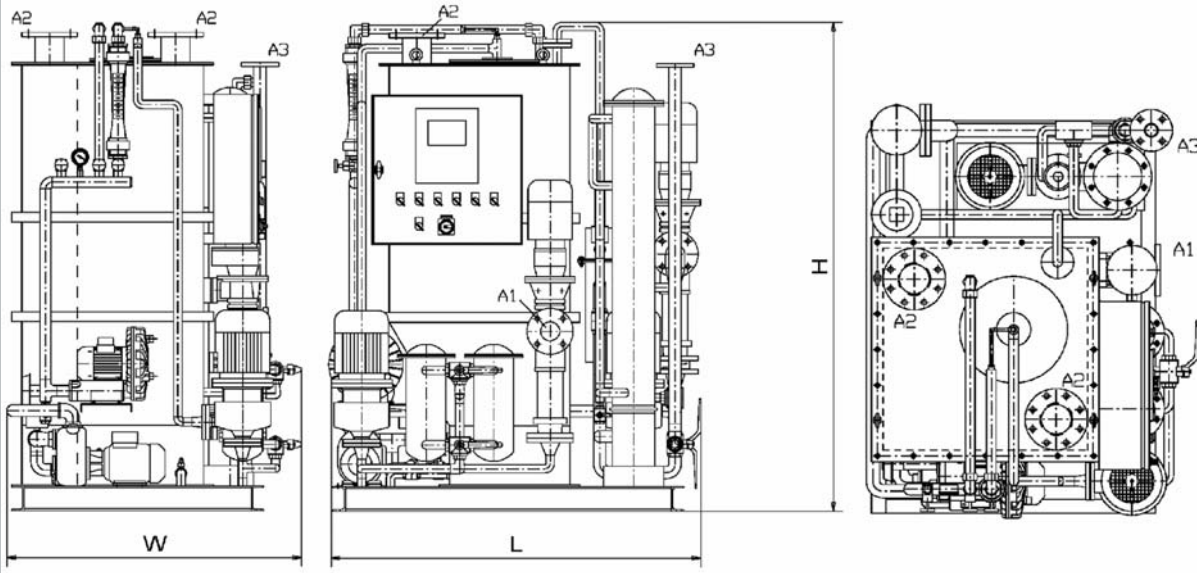

Type	Capacity		main Dimention			Connections		
	Pass.	tot.(m³/d)	L (mm)	W (mm)	H (mm)	A1 (DN)	A2 (DN)	A3 (DN)
DVZ-JZR 25-1-1	25	4,63	1300	1080	1800	25	80	40
DVZ-JZR 50-1-1	50	9,25	1440	1040	2000	25	80	40
DVZ-JZR 50Y-1-1	50	9,25	1440	1080	1800	25	80	40
DVZ-JZR 100-1-1	100	18,5	1680	1540	2000	50	100	40
DVZ-JZR 150-1-2	150	27,75	1680	1540	2000	50	100	40
DVZ-JZR 200-2-4	200	37	2080	1950	2000	50	100	50
DVZ-JZR 250-2-4	250	46,25	2080	1950	2000	50	100	50
DVZ-JZR 300-2-4	300	55,5	2080	1950	2000	50	100	50
DVZ-JZR 400-2-6	400	74	3080	2040	2000	65	100	50
DVZ-JZR 500-3-6	500	92,5	3830	2040	2000	80	125	50

Subject to technical modifications without notice.

DVZ-SERVICES GmbH
 Boschstrasse 9 D-28857 Syke
 Phone: +49 (0)4242 - 16938 - 0
 Fax: +49 (0)4242 - 16938 - 99
 E-Mail: info@dvz-services.de
www.dvz-services.de

DVZ-GROUP



Approved by:



Biological Sewage Treatment Plant

DVZ - SKA “BIOMASTER”-PLUS

- Certified acc. to IMO Resolution MEPC.159 (55)
- In conformity with Alaska and Great Lakes rules
- Advanced BMSU-System (Bio-Mass-Separation-Unit) for excellent treatment results
- Submerged fixed bed bio-film process
- Can be used in gravity systems and all vacuum systems
- Stainless steel design
- Problem-free operation, low operation costs

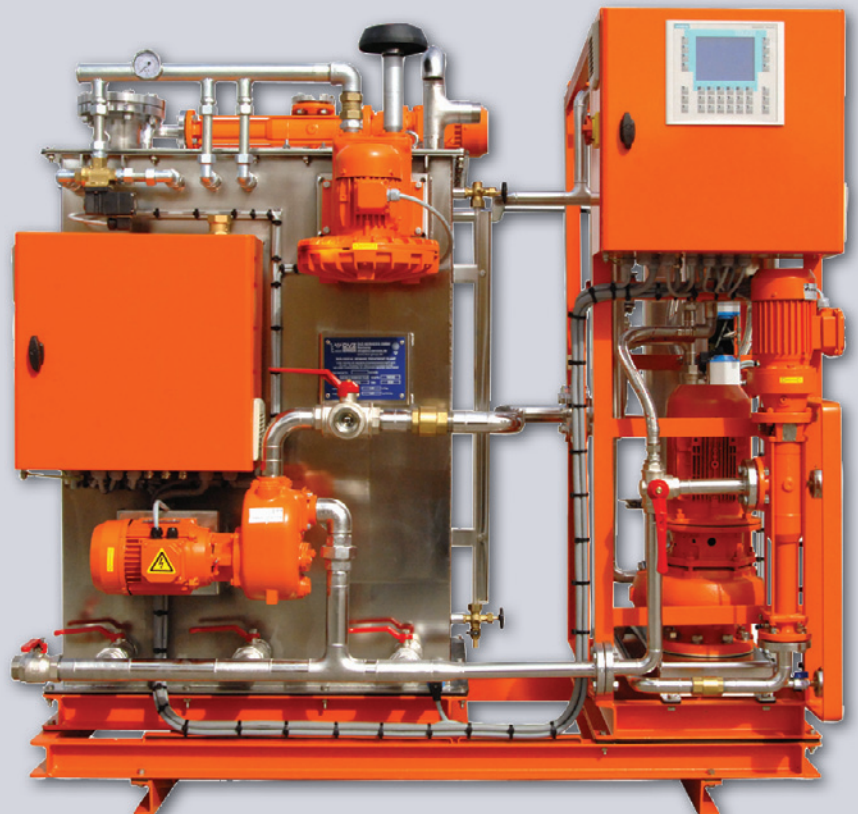

DVZ-SKA-“BIOMASTER”-PLUS

Main dimensions of the standard series skid mounted units

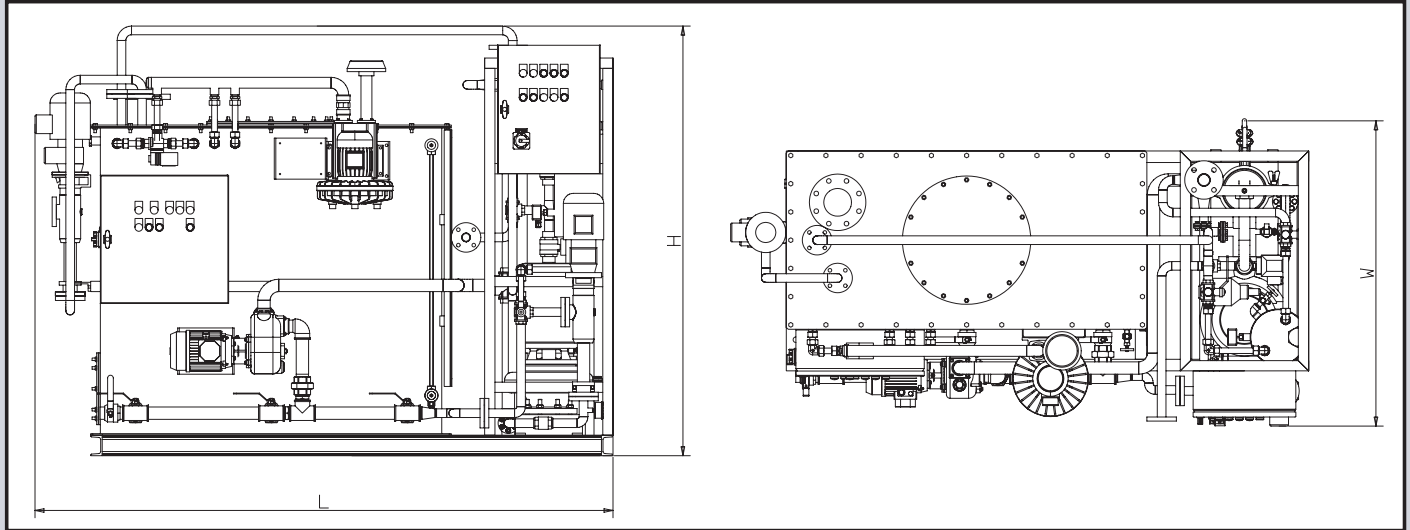

Type	Persons gravity system	Length [mm]	Width [mm]	Height [mm]
SKA-10 PLUS	10	1.815	1.210	1.625
SKA-20 PLUS	20	2.255	1.210	1.625
SKA-30 PLUS	30	2.345	1.465	1.625
SKA-40 PLUS	40	2.510	1.770	1.625
SKA-50 PLUS	50	2.885	1.770	1.625
Up to SKA-800 PLUS or more	800	on request		

Custom made solutions on request (Subject to technical modifications without notice)

Biological Sewage Treatment System **DVZ - SKA** **“BIOMASTER”**[®]

- Development using the state-of-the-art
- "Submerged fixed bed bio-film process"
- Stainless steel design
- Problem-free operation, low operating costs
- Type-tested in accordance with IMO Res. MEPC.2 (VI) Annex (IV) and accepted by the US Coast Guard for non-US flag vessels
- Use of all-aerobic sewage treatment method prevents methane gas forming
- Non-sensitive to long shutdown periods due to continuous activated sludge return
- Can be used in gravity systems and all vacuum systems
- Fixed bed bio-film process excellent treatment results

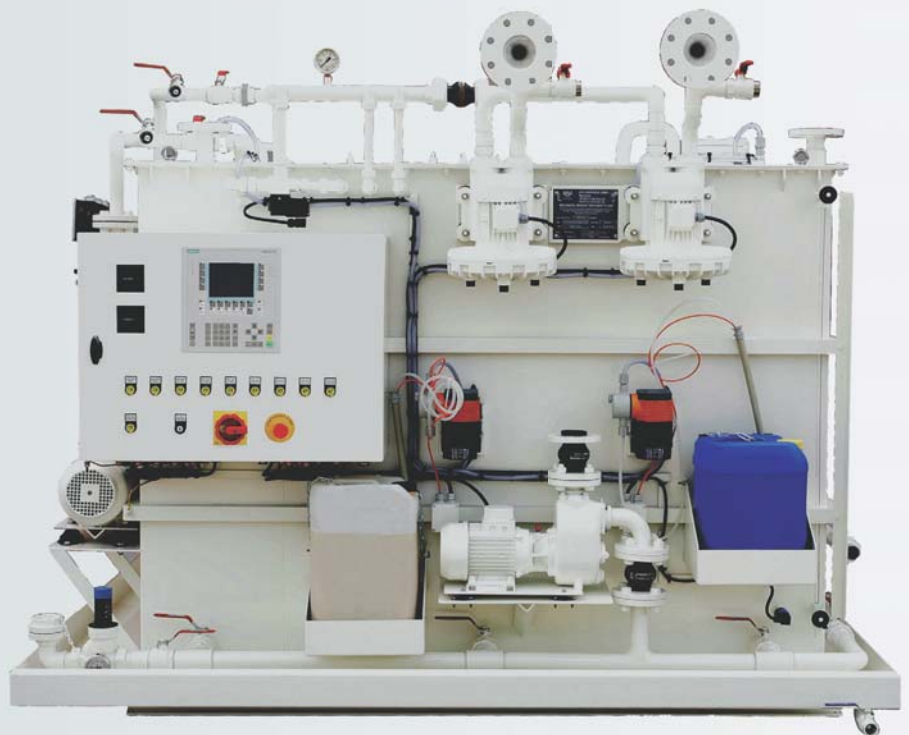

Biological Sewage Treatment System:

DVZ - SKA[®] "BIOMASTER"



System Description

The DVZ-SKA[®] "BIOMASTER" system has been developed using the state-of-the-art "submerged fixed bed bio-film process". The advantage of this treatment method is its extremely large reactive area, which is up to 15 times larger than that of conventional systems. Within a short time this area is occupied by active micro-organisms, thus forming a so-called sheet of bio-mass. The sewage to be cleaned has to flow through this bio-mass and is cleaned using organic methods.

The supply of small oxygen bubbles aerobically stimulates the organisms into extreme activity. Digested sludge formation is prevented by continuously feeding activated sludge back into the active system. The return flow of activated sludge also compensates for an intermittent supply of sewage and allows shutdown periods of approx. 1 week without the biosystem breaking down.

The intrinsic dynamics of the bio-film process are one of its major advantages, i.e. no activators or the like are required to start up the system since the active micro-organisms naturally develop from the sewage. According to international regulations (MARPOL 74/78), raw ship's sewage must not be released into coastal waters or so-called "restricted areas". Ship's sewage from toilets and urinals is designated "black water". "Grey water" is all other water from baths, showers, washbasins and the galley. Galley waste water is fed to the sewage treatment system via a fat separator (DVZ-FT). "Grey water" does not need to be treated, but merely made germ-free by means of disinfecting.



Operating Principle DVZ-SKA „BIOMASTER“[®]

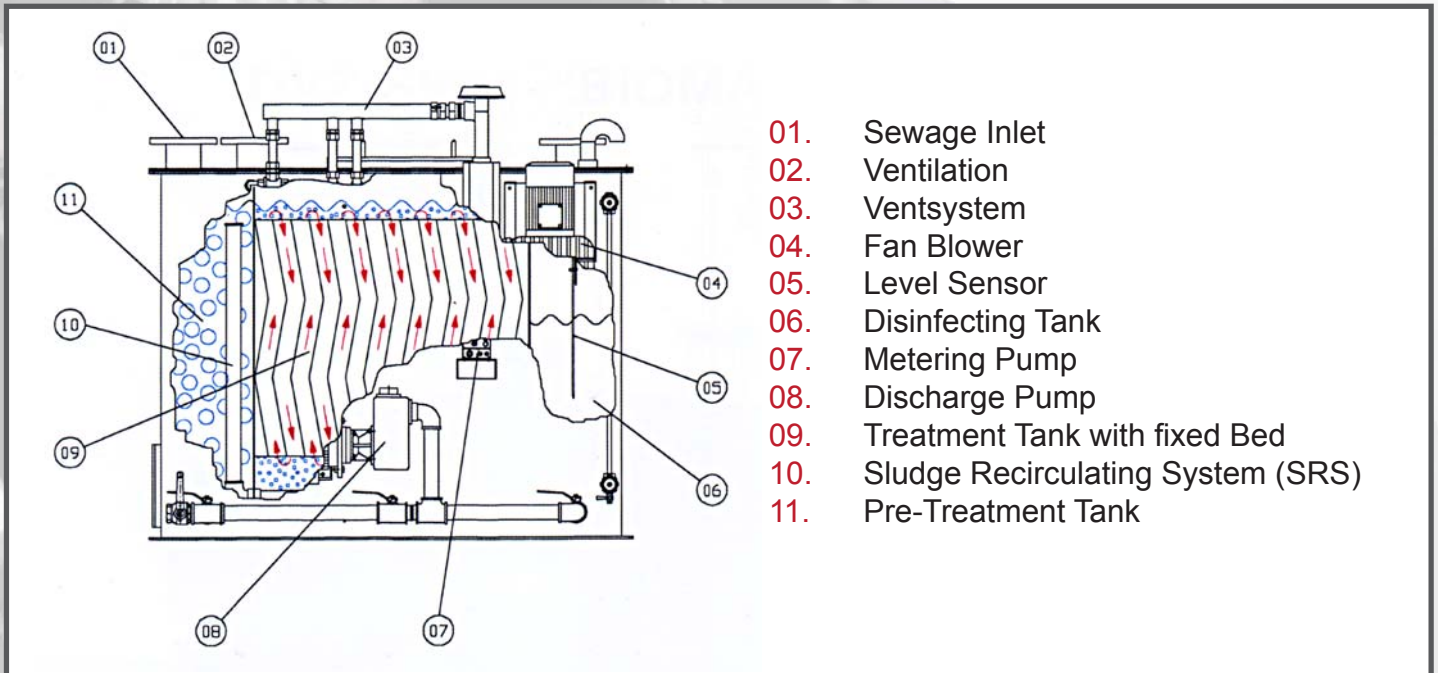

Functional Description

The "black water" is fed through the pipeline using gravity or a vacuum, and flows through the sewage inlet **01** into the pre-treatment tank **11**, where intensive sedimentation and pre-treatment takes place using oxygen, a continuous supply of which is provided by a fan blower **04**. The system is ventilated to the open deck via the ventilation system.

The pre-treated water flows through a special overflow into the treatment tank **09** containing the submerged fixed bed, which is at the centre of the system. The sewage to be treated must circulate through this bed. Fine oxygen bubbles blown in by a special disperser keep the sewage in Suspension and excite the micro-organisms on the surface of the fixed bed into extreme activity, causing almost

complete aerobic-biological degradation of the faecal mass. Remaining activated sludge is fed back into the pre-treatment tank using a sludge siphon and continues to serve as an active bio-mass within the system.

The biologically cleaned sewage is fed to the disinfecting tank **06** via a rising pipe. Adding disinfectant via the metering pump **07** kills off germs and bacteria. When the maximum filling level is reached, the level sensor **05** activates the discharge pump **08**, which empties the tank down to a specified minimum level.

The filling level of the disinfecting tank and the condition of the disinfected water can be visually inspected through a viewing glass.

DVZ-SERVICES GmbH
Boschstrasse 9 D-28857 Syke

Main dimensions of the standard series skid mounted units

(Custom made solutions on request)

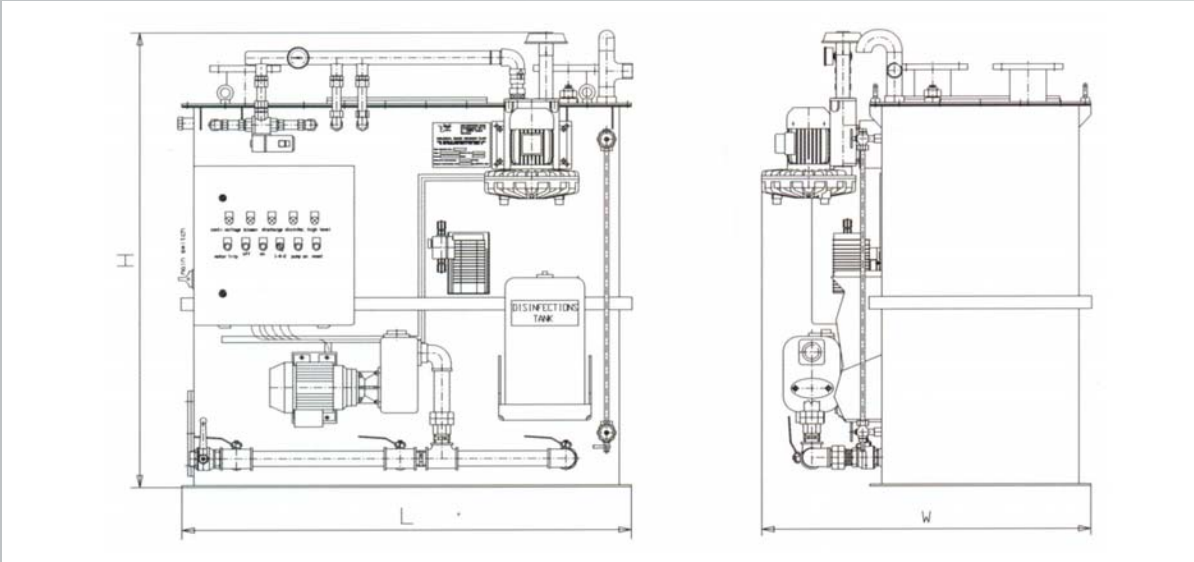

Type	Persons	Length [mm]	Width [mm]	Height [mm]	Empty Weight [kg]	Operation Weight [kg]
SKA 10	10	1.030	1.050	1.490	480	1.080
SKA 20	20	1.410	1.050	1.490	550	1.500
SKA 30	30	1.600	1.350	1.490	650	2.300
SKA 40	40	1.660	1.680	1.490	940	3.110
SKA 50	50	2.032	1.680	1.490	1.040	3.700
up to SKA 800	800	on request				

Subject to technical modifications without notice.

DVZ-SERVICES GmbH
 Boschstrasse 9 D-28857 Syke
 Phone: +49 (0)4242 - 16938 - 0
 Fax: +49 (0)4242 - 16938 - 99
 E-Mail: info@dvz-services.de
www.dvz-services.de



Oily Water Separator DVZ - FSU "OILCHIEF"®

- Type approved according to IMO RESOLUTION MEPC 107 (49)
- Optional with type approved FSU© by-pass function
- Capacity from 150 l/h up to 10.000 l/h
- Jet-wash oil drainage
- Available in stainless steel and shock approved
- Compact design
- Easy installation
- Pump can optionally be used as separate transfer pump



Oily Water Separator:

DVZ - FSU[®] "OILCHIEF"

System Description

The newly developed oily water separator DVZ-FSU-"OILCHIEF" is a fine separation unit constructed as the sum of details and more than 25 years experience in plant design and development that implements highest standard in plant quality. An intelligent interplay of coalescence and fine separation realizes an oil content of less than 15 ppm according to IMO Resolution MEPC 107 (49) in treated water. This limit value is continuously monitored and recorded by an oil-in-water monitor installed on the separator. The well-known features like JET-WASH oil drainage and self-cleaning coalescer are just as much standard features of the DVZ-FSU-"OILCHIEF" as are automatic mode and low maintenance cost.

The flexible plant concept of the DVZ-FSU-"OIL-CHIEF" allows the pump to be used separately, e.g. in the case of high suction height or as transfer pump. The new types of fine separation filter cartridges developed in our laboratory distinguish themselves by a high service life and a high operational reliability. The special surface of the filter cartridges enhances the coalescence characteristic of the dispersed oil and allows a rising in the oil collection dome for subsequent automatic drainage. The inseparable components in the bilge water are retained in the innovatively designed fine separation filter cartridge and allow a treatment of emulsions in accordance with IMO Test Specification. The service life of the cartridge is obviously determined by the level of the contamination and the input concentration of the bilge water. According to the physical term of 'mass balance', the service life is determined by the ratio of untreated water quality to treated water quality.



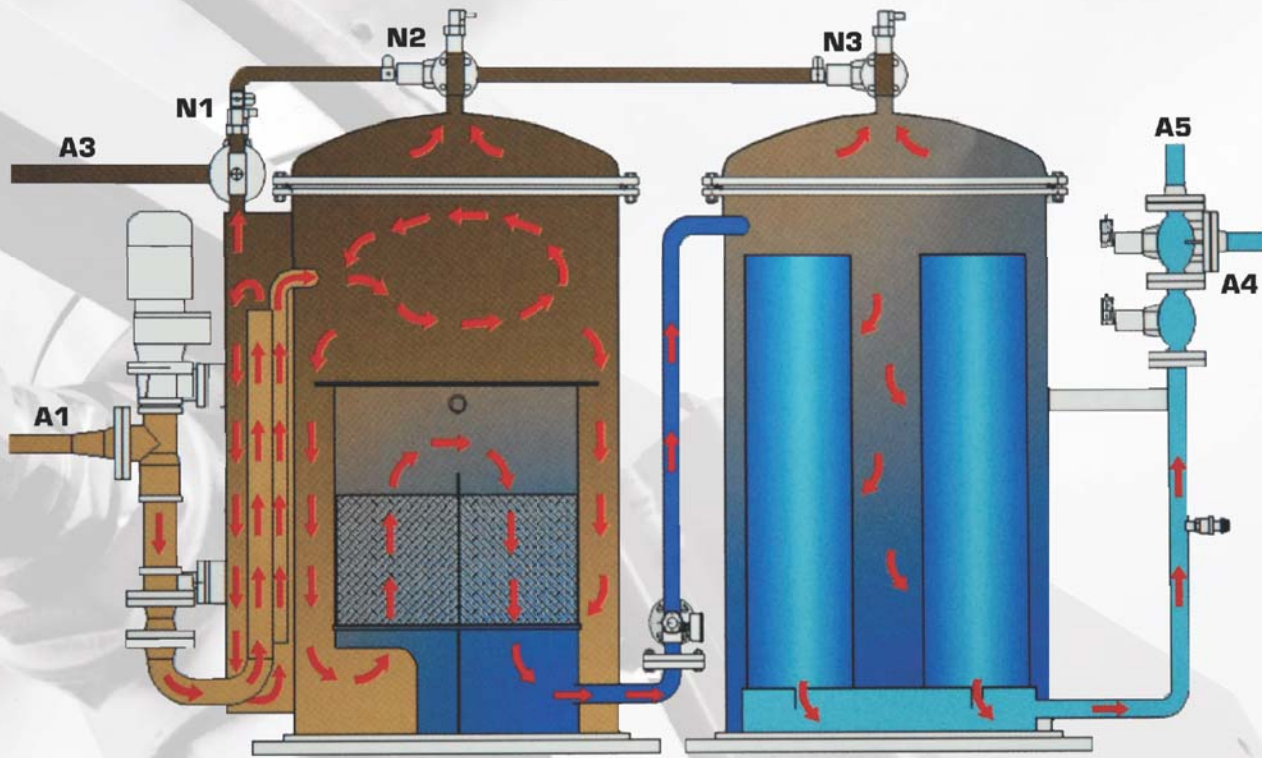

Functional Description

In the newly developed separator generation of the DVZ-FSU- "OILCHIEF" series, the separation process is effected in three stages. The delivery pump P1 sucks the untreated water direct from the bilge or the bilge tank and delivers it to the coarse separation stage 1. This is where the free oil is physically separated from the water and automatically fed into the oil collection tank. The remaining liquid is then delivered to the main separation stage and set in rotation by a hydrocyclone. This centrifuge effect has a positive effect on the separation process. The lighter oil phase accumulates in the centre of the separator and rises up to the oil collection chamber while the heavier water phase moves outwards and then downwards.

When a defined oil quantity has accumulated in the oil collection chamber, it is automatically discharged to the waste oil tank. During the process stage 2, the oil-water phase is diverted by 180° and routed vertically from the bottom to the top, in a physically logical way, through a so-called coalesces, where tiniest oil drops combine here and then rise by gravity up to the oil collection chamber for separation. Solids, which may reach the separator with the oil-water phase, settle in the bottom area of the separator and can be drained off as required.

The special lay- out of the coalesces stage and the special geometry of the coalescence inserts ensure that a blockage caused by dirt particles is almost impossible and thus allow a long service life and thus a reduction of operating and maintenance costs. In the downstream fine separation stage (DVZ-FSU), respectively process stage 3, emulsified oil is separated from the water phase.

The core components of process stage 3 are the newly developed, scientifically designed and tested fine separation filter cartridges (DVZ-FSC). They allow the treatment of oilwater mixtures in accordance with IMO resolution MEPC 107 (49) with a residual oil content of less than 15 ppm.

The special feed flow direction and the special do-sign of the fine separation filter cartridges allows a high separation level and thus a long service life. Available as an option is a typetested fine separation bypass function, which automatically bypasses the fine separation stage when the oil content is less than a preset level and thus reduces the cost and increases the operational reliability. After process stage 3, the treated water is continuously monitored by an oil-in-water monitor and automatically routed, by a 3-way valve, overboard or back to the bilge if the oil limit value is exceeded.

DVZ-SERVICES GmbH
Boschstrasse 9 D-28857 Syke

Phone: +49 (0)4242 - 16938 - 0
Fax: +49 (0)4242 - 16938 - 99
E-Mail: info@dvz-services.de
www.dvz-services.de

Main dimensions of the standard series (special design on request)

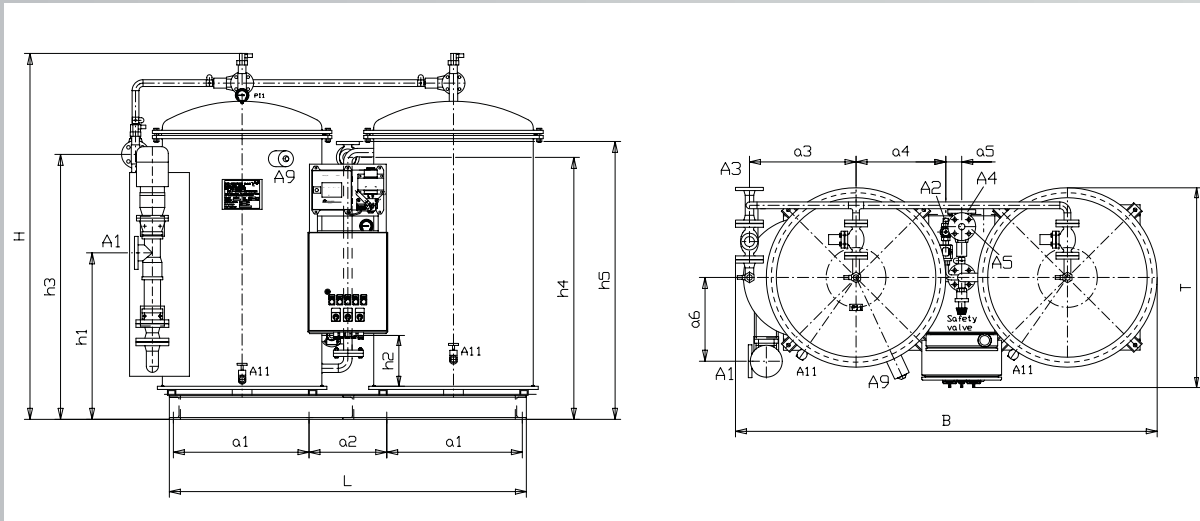

TYPE	FSU 250	FSU 500	FSU 1000	FSU 2500	FSU 5000	FSU 10000
Capacity [l/h]	250 l/h	500 l/h	1000 l/h	2500 l/h	5000 l/h	10000 l/h
B [mm]	960	1155	1155	1620	2120	3050
H [mm]	1200	1250	1350	1640	1840	1920
T [mm]	765	835	835	890	1060	1350
L [mm]	820	960	960	1310	1790	2550
a1 [mm]	275	335	335	470	680	990
a2 [mm]	230	250	250	350	380	520
a3 [mm]	210	260	260	388	535	765
a4 [mm]	252	290	290	410	530	755
a5 [mm]	125	155	155	90	110	185
h1 [mm]	560	650	650	655	840	980
h2 [mm]	240	250	250	255	255	275
h3 [mm]	775	880	980	1260	1460	1450
h4 [mm]	975	975	1075	1295	1320	1290
h5 [mm]	1010	1010	1110	1375	1410	1390
d [mm]	d 324	d 406	d 406	d 600	d 800	d 1250
A1	DN 25	DN 25	DN 25	DN 50	DN 50	DN 80
A2	R 3/4"	R 3/4"	R 3/4"	R 3/4"	R 3/4"	R 3/4"
A3,A4,A5	R 3/4"	R 3/4"	R 3/4"	DN 25	DN 25	DN 40
Empty weight kg	360	460	480	840	1120	2260
Operation weight kg	490	684	728	1700	2500	5460

Subject to technical modifications without notice.

DVZ-SERVICES GmbH
 Boschstrasse 9 D-28857 Syke
 Phone: +49 (0)4242 - 16938 - 0
 Fax: +49 (0)4242 - 16938 - 99
 E-Mail: info@dvz-services.de
www.dvz-services.de

DVZ-GROUP



Approved by:

