

FLOAT AND THERMOSTATIC STEAM TRAPS

FLT32

(Cast steel 1/2" - 1"; DN 15 - 25)

DESCRIPTION

FLT32 float and thermostatic (integral air vent) steam traps series are designed for all types of low and high pressure steam heating and process equipment.

Typical applications include unit heaters, heat exchangers, driers, jacketed vessels and all the applications where continuous drainage is essential.

Connections are female screwed or flanged for horizontal or vertical installation.

MAIN FEATURES

Modulating discharge.

Discharges condensate at steam temperature.

Unaffected by sudden or wide load and pressure changes.

Excellent air discharge (by thermostatic air vent).

OPTIONS: SLR – steam lock release.
Equalizing plug or vent connection.

USE: Saturated and superheated steam.

AVAILABLE

MODELS: FLT32-4,5, 10, 14 and 21.

SIZES: 1/2" to 1" – DN 15 to 25.

CONNECTIONS: Female screwed ISO7/1 Rp (BS21)
Flanged EN 1092-1 PN40 or ANSI.

INSTALLATION: Standard horizontal installation –
From right to left FLT32 (R-L).

Upon request:

-horizontal installation with the flow from left to right (L-R).

-vertical installation with the flow from top to bottom (V).

MAX. DIFFERENTIAL PRESSURE

FLT32-4,5 : 4,5 bar

FLT32-10 : 10 bar

FLT32-14: 14 bar

FLT32-21: 21 bar

CE MARKING – GROUP 2 (PED – European Directive)	
PN40	Category
DN 15 to DN 25	SEP



BODY LIMITING CONDITIONS

FLANGED PN40 / ANSI 300 lb *	FLANGED ANSI 150 lb **	RELATED TEMPERATURE
		ALLOW. PRESS.
37,1 bar	15,4 bar	100 °C
33,3 bar	13,8 bar	200 °C
30,4 bar	12,1 bar	250 °C
27,6 bar	10,2 bar	300 °C

PMO – Max. operating pressure 32 bar

TMO – Max. operating temperature 250 °C

*Acc. to EN1092-1:2007 ; **Acc. to EN1759-1:2004

Body limiting conditions PN40 or below, depending on the type of connection adopted. Rating PN40 for thread, SW and BW.

FLOW RATE CAPACITY (kg/h)

MODEL	SIZE DN	DIFFERENTIAL PRESSURE (bar)														
		0,5	1	1,5	2	3	4,5	6	7	8	9	10	12	14	16	21
FLT32-4,5	15-25	230	330	400	440	535	630	–	–	–	–	–	–	–	–	–
FLT32-10	15-25	150	200	250	280	340	400	460	495	520	550	595	–	–	–	–
FLT32-14	15-25	120	150	190	220	260	320	380	400	425	440	480	510	550	–	–
FLT32-21	15-25	60	80	90	115	135	160	190	200	220	230	240	260	270	290	300

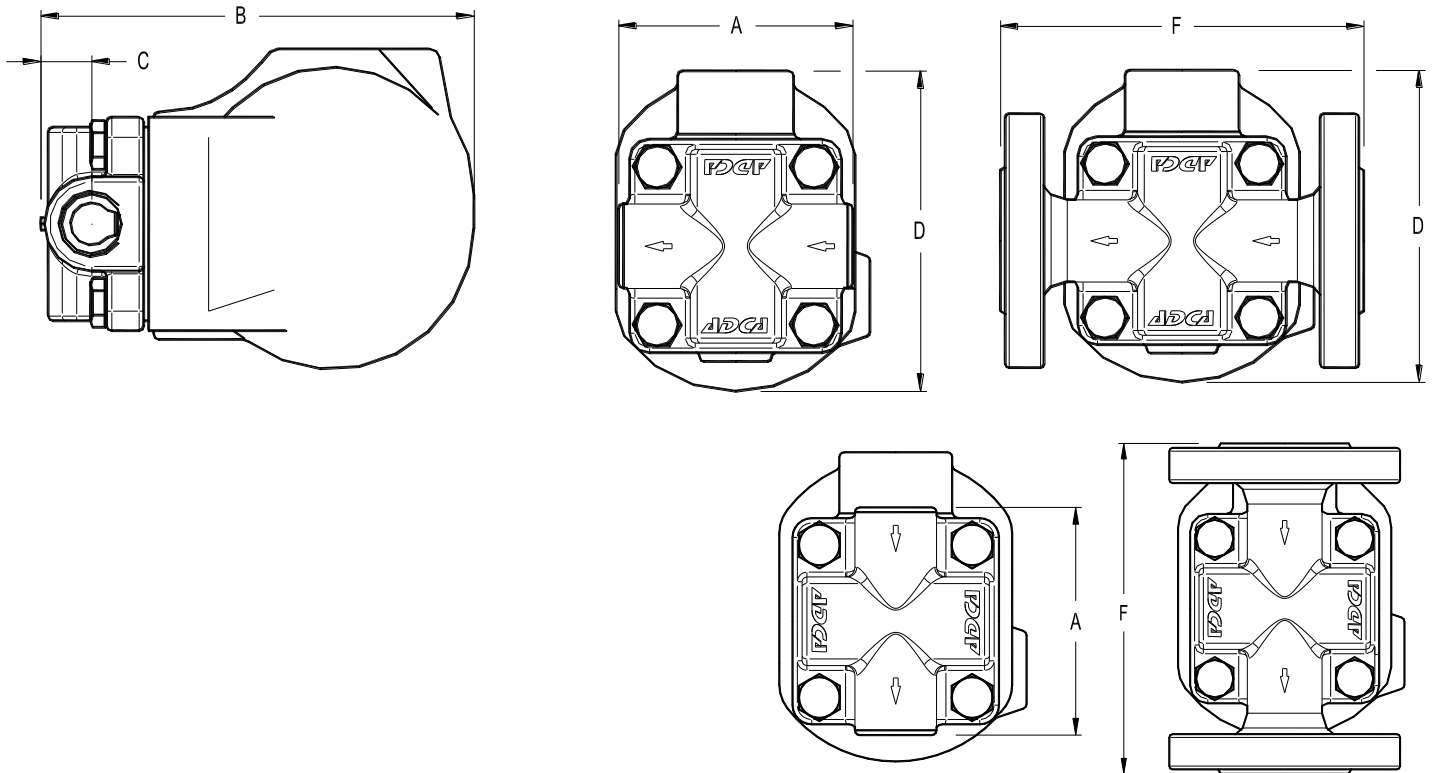

Vertical Installation (V)

DIMENSIONS (mm)											
Screwed						EN PN16 / 40		ANSI 150 lb		ANSI 300 lb	
SIZE	A	B	C	D	WGT. (kg)	F	WGT. (kg)	F	WGT. (kg)	F	WGT. (kg)
1/2" – DN 15	95	178	23	128	5,2	150	6,7	150	6,2	150	7
3/4" – DN 20	95	178	23	128	5,2	150	7,4	150	6,6	150	8,2
1" – DN 25	95	178	23	128	5,2	160	7,8	160	7,4	160	9

MATERIALS		
POS. N°	DESIGNATION	MATERIAL
1	Body	GP240GH / 1.0619
2	Cover	GP240GH / 1.0619
3	*Gasket	Stainless steel / Graphite
4	*Seat	AISI 410 / 1.4006
5	*Valve	AISI 440C / 1.4125
6	*Lever	AISI 304 / 1.4301
7	*Float	AISI 304 / 1.4301
8	*Air vent	Stainless st. (bimetallic)
9	Bolts	Steel 8.8

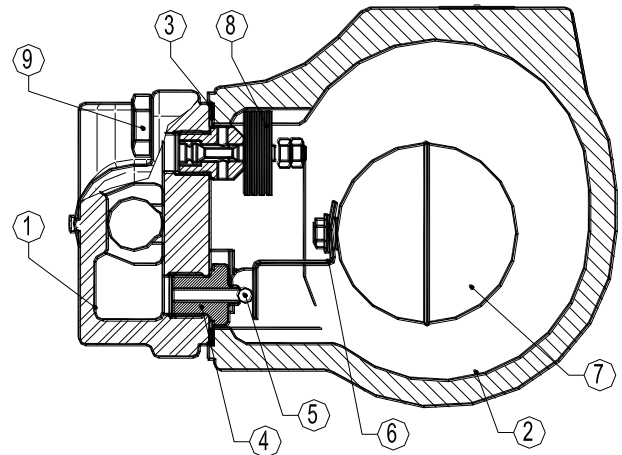

* Available spare parts.